



VINYL RAILINGS



The Goddard School



CERTIFIED
ICC-ES AC174
2006 INTERNATIONAL RESIDENTIAL CODE (IRC)
2006 INTERNATIONAL BUILDING CODE (IBC)
1999 BOCA NATIONAL BUILDING CODE
Allusions® Vinyl Railing System™
meets the highest building
codes in the nation!

ICC-ES AC174



ILLUSIONS® VINYL RAILING SYSTEM™ IS FULLY ICC-ES AC174 CERTIFIED

Evaluation Scope

- Compliance with the following codes:
- 2006 International Building Code® (IBC)
 - 2006 International Residential Code® (IRC)

Properties Evaluated

- Structural
- Durability
- Surface-burning characteristics

*ICC-ES-2995
CCRR-0143*

Uses

The **Illusions Vinyl Railing System™** described in this report is for exterior use as guards for balconies, porches, decks and stairs in buildings of Type V-B (IBC) construction and other types of construction in applications where untreated wood is permitted by IBC Section 1406.3 or in buildings constructed in accordance with the IRC.

Description

The **Illusions® Vinyl Railing System™** is composed of polyvinyl chloride (PVC) which is extruded, in accordance with the approved quality control manual, into prefinished railing system components. The system components are available in white, beige or gray.

The **Illusions® Vinyl Railing System™** is composed of top rails with aluminum "H" shaped inserts, bottom rails, and either square or colonial-shaped balusters. The inserts are 1.73 inches (43.9 mm) wide by 3.18 inches (80.8 mm) deep, and have 0.07-inch-thick (1.78 mm) flanges and a 0.10-inch-thick (2.54 mm) web. The inserts are made of Aluminum Alloy 6005-T5 meeting ASTM B 221. Four styles of **Illusions®** railings are available: Traditional square balusters with rectangular top rails; Traditional square balusters with T-Rail top rails; Colonial Spindle balusters with rectangular top rails; and Colonial Spindle balusters with T-Rail top rails. The rectangular top rails and the bottom rails are 2 inches (51 mm) wide by 3.5 inches (89 mm) deep. The T-Rail top rails have a wider top, resulting in an overall size of 3.5 inches (89 mm) wide by 3.5 inches (89 mm) deep. The **Illusions® Vinyl Railing System™** is recognized for guardrails having a maximum height of 42 inches (107 cm) as shown in Table 1. The railings provide for 3.42-inch-wide (86.9 mm) openings between the 1-1/2 inch (38.1 mm) square sections of the thermoformed hollow PVC Colonial balusters and the co-extruded hollow PVC Traditional balusters. The bottom and top rails have a 0.12-inch (3.05 mm) wall thickness, and the Traditional and Colonial balusters have a 0.08-inch (2.03 mm) wall thickness. See Figure 2 for typical component cross sections.

The top and bottom rails are fastened to the supporting structure using 2.5-inch-tall-by-2.75-inch-wide (64 mm by 70 mm) nylon brackets. The brackets have four screw holes used to fasten the brackets to the supports, a resting flange at the bottom, and a fastening flange on each side with three slotted screw holes each. The brackets are designed for mounting deck railings and stair railings to fixed wall surfaces or to braced columns.

Durability

When subjected to weathering, insect attack and other decaying elements, material used to manufacture the **Illusions® Vinyl Railing System™** is equivalent to preservative-treated or naturally durable lumber when used in locations described in Section 2.0 of this report. The **Illusions® Vinyl Railing System™** has been evaluated for a temperature range of -20°F to 125°F (-29°C to 52°C).

Surface Burning Characteristics

When tested in accordance with ASTM E 84, the **Illusions® Vinyl Railing System™** has a flame-spread index of no greater than 200.

Design and Installation

General: Installation of the **Illusions® Vinyl Railing System™** must comply with this report and the manufacturer's published installation instructions. A copy of these instructions must be available on the jobsite at all times during installation. When the manufacturer's published installation instructions differ from this report, this report governs.

Design: The **Illusions® Vinyl Railing System™** is satisfactory to resist the loads specified in IBC Section 1607.7.1 and IRC Table R301.5, when installed at a maximum edge-of-structure-to-edge-of-structure spacing as prescribed in Table 1 of this report.

Installation: The **Illusions® Vinyl Railing System™** has been evaluated for installation between two fixed points, such as walls or columns. The top rails must be reinforced with aluminum "H" shaped inserts, which are provided with the rails. The rails must be installed using the mounting plates supplied by Eastern Wholesale Fence Co., Inc., mounted on the supports at the appropriate heights for the bottom and top rails, with four No.10 by 1-1/2 inch-long (38.1 mm) panhead, stainless steel screws per bracket supplied by the manufacturer. The rails must be secured to the mounting brackets with two No. 10 by 3/4-inch (19.1 mm) stainless steel, pan head, self-tapping screws, making sure the screws engage and penetrate through the aluminum "H" shaped inserts. At stairs, the rails are installed in the same manner, with the bottom rail installed 2 inches above the risers. The attachment method described above for brackets to supports is for fasteners embedded into a wood substrate having a specific gravity of 0.50 (minimum), to a minimum depth of 1-3/8 inches (34.9 mm). Additional attachment methods are outside the scope of this report and are required to be submitted to the code official for approval. See Figure 1 for typical railing system installation.

Conditions of Use

The **Illusions® Vinyl Railing System™** described in this report complies with, or is a suitable alternative to what

is specified in, those codes listed in Section 1.0 of this report, subject to the following conditions:

The **Illusions® Vinyl Railing System™** described in this report is limited to exterior use as guards for balconies, porches, decks and stairs in buildings of Type V-B (IBC) construction and other types of construction in applications where untreated wood is permitted by IBC Section 1406.3, or in buildings constructed in accordance with the IRC.

Installation must comply with this report, the manufacturer's published installation instructions and the applicable code. Only those fasteners and fastener configurations described in this report have been evaluated for the installation of the **Illusions® Vinyl Railing System™**. When the manufacturer's published installation instructions differ from this report, this report governs.

The determination of compatibility of the fasteners, metal post mount components and other metal hardware with the supporting construction, including chemically treated wood, is subject to approval by the code official.

5.4 Adjustment factors outlined in the AF&PA National Design Standard and applicable codes must not apply to the allowable capacity and maximum spans for the **Illusions® Vinyl Railing System™**.

5.5 The **Illusions® Vinyl Railing System™** must be fastened directly to supporting construction. Where required by the code official, engineering calculations and construction documents consistent with this report must be submitted for approval. The calculations must verify that the supporting construction complies with applicable building code requirements and is adequate to resist the loads imparted upon it by the products and systems discussed in this report. The documents must contain details of the attachment to the supporting structure consistent with the requirements of this report. The documents must be prepared by a registered design professional where required by the statutes of the jurisdiction in which the project is to be constructed.

5.6 The top rail of the **Illusions® Vinyl Railing System™** must not be permitted to be used as a handrail for stairways or ramps.

5.7 Posts are outside the scope of this report.

5.8 The **Illusions® Vinyl Railing System™** components are produced in Calverton, New York, under a quality control program with inspections by Architectural Testing, Inc. (AA-676).

Evidence Submitted

Data in accordance with the ICC-ES Acceptance Criteria for Deck Board Span Ratings and Guardrail Systems (Guards and Handrails) (AC174), dated February 2008 (editorially revised April 2008).

TABLE 1 – MAXIMUM GUARDRAIL SYSTEM SPANS¹

GUARDRAIL SYSTEM	GUARDRAIL TYPE	APPLICABLE BUILDING CODE ²		MAXIMUM SPAN ^{3,4} (Inches)
		IBC	IRC	
Colonial balusters with maximum 42-inch-high Rectangular or T-Rail top rail	Level	Yes	Yes	92
	Stair	Yes	Yes	87.5
Traditional balusters with maximum 42-inch-high Rectangular or T-Rail top rail	Level	Yes	Yes	92
	Stair	Yes	Yes	87.5

1 The ability of the supporting construction to resist the reaction from guardrail loads must be justified to the satisfaction of the code official.

2 Indicates compliance with the respective building codes.

3 Maximum allowable span has been adjusted for durability. No further increases are permitted.

4 Maximum span is measured from edge-of-support-to-edge-of-support. It is recommended that separate specimens be used for each exposure time.

ASTM F964-09



WHAT IS ASTM F964-09?

Scope

ASTM F964-09 is considered one of the “end all, beat all” testing specification for vinyl railing and fence quality. The purpose of this specification is to establish a recognized standard of quality for exterior vinyl profiles for use in assembling agricultural, commercial, and residential fencing and railing. This specification covers **Illusions® Vinyl Railing System™** sections and the EverStrong® Profiles used to fabricate them.

Materials

Illusions® Vinyl Railing System™ Products are manufactured using rigid poly vinyl chloride (PVC) compounds for exterior-profile extrusions that meet the requirements of ASTM Specification D4216.

Manufacture

Illusions® Vinyl Railing System™ Products are manufactured to meet cell Class 1-32333-3 as defined in Specification D4216. **Illusions®** compounds have higher cell classification because one or more properties are superior to those used in standard acceptable compounds.

Color/Consistency Testing – The PVC compound in extruded section shall maintain uniform color and be free of any visual surface or structural changes, such as peeling, chipping, cracking, flaking, or pitting after weathering at intervals of six months and one year for white and for six months, one year, and two years for all other colors in hot, dry climate such as Phoenix, AZ; a hot humid climate, such as Miami, FL; and a temperate northern climate, when tested in accordance with ASTM Performance Weathering Requirements (TABLE 1).

Weathering Testing – The PVC compound shall have a minimum impact resistance of 0.6 in.-lb/mil (2670 J/m) after weathering six months and one year in a hot, dry climate such as Phoenix, AZ; a hot, humid climate, such as Miami, FL; and a temperate northern climate, when tested in accordance with ASTM Performance Weathering Requirements. The PVC compound shall have successfully met the weathering requirements prescribed for six months at each climatic testing site prior to use in production of exterior-profile extrusions, when tested in accordance with ASTM Performance Weathering Requirements (TABLE 1).

ASTM Specifications Met

- D256** – To determine Izod impact properties
- D618** – Practice for Conditioning Plastics for Testing
- D635** – Test Method for Rate of Burning and/or Extent and Time of Burning of Plastics in a Horizontal Position
- D638** – To determine tensile properties
- D648** – To determine heat distortion temperature
- D696** – Test Method for Coefficient of Linear Thermal Expansion of Plastics Between 030°C and 30°C with a Vitreous Silica Dilatometer
- D790** – To determine flexural properties
- D792** – To determine specific gravity
- D883** – Terminology Relating to Plastics
- D1435** – Practice for Outdoor Weathering of Plastics
- D1600** Terminology for Abbreviated Terms Relating to Plastics
- D1784** – Specification for Rigid Poly (Vinyl Chloride) (PVC) Compounds and Chlorinated Poly (Vinyl Chloride) (CPVC) Compounds
- D7032** – Standard Specification for Establishing: Performance Ratings for Wood-Plastic Composite Deck Boards and Guardrail Systems (Guards or Handrails)
- D1761** – Standard Test Methods for Mechanical Fasteners in Wood: Used to test rail mounting brackets in PVC sleeved pressure treated wood posts.
- D1898** – Practice for Sampling of Plastics
- D2240** – To determine Shore hardness values
- D2244** – Practice for Calculation of Color Tolerances and Color Differences from Instrumentally Measured Color Coordinates
- D2565** – Practice for Xenon-Arc Exposure of Plastics Intended for Outdoor Applications
- D4216** – Material Class Number1-32333-3. To establish Cell Classification of PVC material. Illusions compounds have higher cell classification because one or more properties are superior to those used in standard acceptable compounds
- D4226** – Test Methods for Impact Resistance of Rigid

Poly-(Vinyl Chloride) (PVC) Building Products
D4726 – Specification for Rigid Poly(Vinyl Chloride) (PVC) Exterior-Profile Extrusions Used for Assembled Windows and Doors
E-84-04 – Used to determine the flame spread value of PVC material; **Illusions®** burn rate is significantly lower than allowed value

Quality Assurance

Illusions® Vinyl Railing System™ Products are run through a series of dimensional and color tests that are performed at least every two hours. Testing includes; flattening, extrusion quality, impact resistance, warp, color comparison with standard color samples, capstock thickness, and bond testing. All will be done at the startup of a production and once per shift thereafter with a minimum of two tests per 24 hours of production.

TABLE 1 - Required Exposures for PVC Extrusions - In Process

Color of PVC Extrusions	Exposure Climate	Required Exposure Times, Months*
White	hot, dry (Phoenix, AZ)	6 and 12
	hot, humid (Miami, FL)	6 and 12
	northern temperate	6 and 12
Any other color	hot, dry (Phoenix, AZ)	6, 12 and 24
	hot, humid (Miami, FL)	6, 12 and 24
	northern temperate	6, 12 and 24

*It is recommended that separate specimens be used for each exposure time.

THESE ARE THE RESULTS FROM AN ACCELERATED WEATHER TESTING CHAMBER IN LABORATORY CONDITIONS

The Illusions® Vinyl Fence Advantage

This test is run according to ASTM Standard G-155, Cycle #1. All Illusions® Vinyl Fence Product is guaranteed to be made from 100% Pure Virgin Vinyl and assembled according to ASTM F964. Please note the difference in color retention and be assured, Illusions® Vinyl Fence will have uniformed color and be free of any visual surface or structural changes such as: peeling, chipping, cracking, flaking, or pitting after weathering.

Be assured! Insist on *Illusions® Vinyl Fence* Products.

Competitor:
450 Hrs.
(4-5 Years)

Illusions®:
1000 Hrs.
(10-11 Years)

NFA Weather Test Illusions ©2008

WEBSITE



Page 2 of 4

ICC EVALUATION SERVICE
ICC-ES Evaluation Report

ESR-2995
Issued October 1, 2009

ICC-ES Evaluation Report
This report is subject to re-examination in one year.

ICC-ES Evaluation Report
www.icc-es.org | (800) 431-5887 | (540) 699-0543

REPORT HOLDER:
EASTERN WOODSALE FENCE CO., INC.
1000 W. 14th St., New York, NY 10011
(212) 696-0571
www.easternwoodsale.com

EVALUATION SUBJECT:
ILLUSIONS VINYL RAILING SYSTEM

1.0 EVALUATION SCOPE
Compliance with the following codes:
• 2006 International Building Code (IBC)
• 2006 International Residential Code (IRC)
Proprietary evaluated:
• Durability
• Surface burning characteristics

2.0 Description
The Illusions Vinyl Railing System is a railing system consisting of a top rail, a bottom rail, and pickets. The top rail is made of a high-strength, impact-resistant material. The bottom rail is made of a high-strength, impact-resistant material. The pickets are made of a high-strength, impact-resistant material. The railing system is designed to provide a safe and attractive solution for both commercial and residential applications.

Illusions Vinyl Railing System

Installation Instructions

Tools Needed to Complete Installation:

- Measuring Tool
- Power Drill
- 1/2" Wood Screws for Base of Submerging Height of Sections

RAILING SYSTEM ORDER SHEET

Illusions Vinyl Railing System

COMPANY: _____

ADDRESS: _____

CITY: _____

STATE: _____

ZIP: _____

PHONE: _____

QUOTE ORDER

MATERIALS NEEDED FOR CERTIFICATION

Illusions Vinyl Railing System™ meets the highest building code standards in the residential applications. It is sure to provide a safe and attractive solution for all of your railing needs.

To properly qualify for the ICC-ES AC174 Certification, the Illusions Vinyl Railing System must be installed as a complete system. In order to complete this system, here is a list of the items that are required:

- Railing Panel (36" and 42" High)
- Bracket Kits
- Screw Kit with Required Installation Instructions

USAGE
Required. Available in 6" or 8" Panels, 1-1/2" or 2" Spacing or Colonial Pickets Spacing. Available in 36" or 42" Height. Available in White (W), Beige (B), Gray (G), or Mix 'n' Match (M).
IMPORTANT: MUST CHECK LOCAL CODE FOR HEIGHT REQUIREMENTS. One Hand Stair Rail Bracket Kit per section. One Screw Kit per section. Installation instructions included with every screw kit.

CHECK THE RAILINGS WEBSITE FOR SPEC SHEETS!



RAILINGS

Illusions Vinyl Railing System™

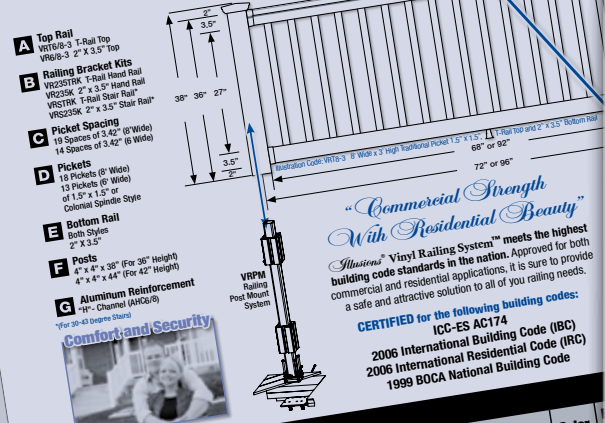

"Commercial Strength With Residential Beauty"

Illusions Vinyl Railing System™ meets the highest building code standards in the nation. Approved for both commercial and residential applications, it is sure to provide a safe and attractive solution to all of your railing needs.

CERTIFIED for the following building codes:
ICC-ES AC174
2006 International Building Code (IBC)
2006 International Residential Code (IRC)
1999 BOCA National Building Code

Item No.	Description	Color
VRT6-3	3' High Traditional Pkt. 1-1/2" x 1-1/2", T-Rail Top and 2"x3.5" Bottom Rail, 6" Wide	White
VRT8-3	3' High Traditional Pkt. 1-1/2" x 1-1/2", T-Rail Top and 2"x3.5" Bottom Rail, 8" Wide	White
VR6-3	3' High Traditional Pkt. 1-1/2" x 1-1/2", 2"x3.5" Top and Bottom Rail, 6" Wide	White
VR8-3	3' High Traditional Pkt. 1-1/2" x 1-1/2", 2"x3.5" Top and Bottom Rail, 8" Wide	White
VRTBC-3	3' High Colonial Spindle Pkt., T-Rail Top and 2"x3.5" Bottom Rail, 6" Wide	White
VRTBC-3	3' High Colonial Spindle Pkt., T-Rail Top and 2"x3.5" Bottom Rail, 8" Wide	White
VRBC-3	3' High Colonial Spindle Pkt., 2"x3.5" Top and Bottom Rail, 6" Wide	White
VRBC-3	3' High Colonial Spindle Pkt., 2"x3.5" Top and Bottom Rail, 8" Wide	White
VRST6-3	3' High Traditional Stair Rail Section, T-Rail Top and 2"x3.5" Bottom Rail, 6" Wide	White
VRST8-3	3' High Traditional Stair Rail Section, T-Rail Top and 2"x3.5" Bottom Rail, 8" Wide	White
VRSE-3	3' High Colonial Stair Rail Section, T-Rail Top and 2"x3.5" Bottom Rail, 6" Wide	White
VRSE-3	3' High Colonial Stair Rail Section, T-Rail Top and 2"x3.5" Bottom Rail, 8" Wide	White
VRSTBC-3	3' High Colonial Stair Rail Section, 2"x3.5" Top and Bottom Rail, 6" Wide	White
VRSTBC-3	3' High Colonial Stair Rail Section, 2"x3.5" Top and Bottom Rail, 8" Wide	White
VRSC-3	3' High Colonial Stair Rail Section, 2"x3.5" Top and Bottom Rail, 6" Wide	White
VRSC-3	3' High Colonial Stair Rail Section, 2"x3.5" Top and Bottom Rail, 8" Wide	White

* - In Stock Item

Illusions Vinyl Railing System

Installation Instructions

Tools Needed to Complete Installation:

- Measuring Tool
- Power Drill
- 1/2" Wood Screws for Base of Submerging Height of Sections

IMPORTANT NOTE:
• Please refer to the product manual for all installation instructions.
• Please refer to the product manual for all installation instructions.
• Please refer to the product manual for all installation instructions.

10% Additional for Beige, Gray and Mix 'n' Match™

THE SYSTEM



Illusions® VINYL RAILING SYSTEM™

- A Top Rail**
VRT6/8-3 T-Rail Top
VR6/8-3 2" X 3.5" Top
- B Railing Bracket Kits**
VR235TRK T-Rail Hand Rail
VR235K 2" x 3.5" Hand Rail
VRSTRK T-Rail Stair Rail*
VRS235K 2" x 3.5" Stair Rail*
- C Picket Spacing**
19 Spaces of 3.42" (8' Wide)
14 Spaces of 3.42" (6' Wide)
- D Pickets**
18 Pickets (8' Wide)
13 Pickets (6' Wide)
of 1.5" x 1.5" or
Colonial Spindle Style
- E Bottom Rail**
Both Styles
2" X 3.5"
- F Posts**
4" x 4" x 38" (For 36" Height)
4" x 4" x 44" (For 42" Height)
- G Aluminum Reinforcement**
"H"- Channel (AHC6/8)
*(For 30-43 Degree Stairs)

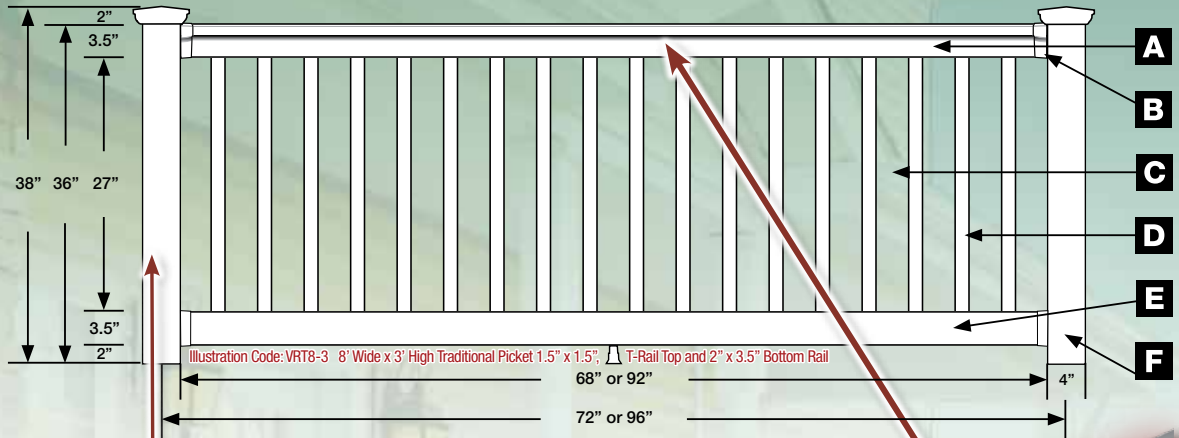

*“Commercial Strength
With Residential Beauty”*

Illusions® Vinyl Railing System™ meets the highest building code standards in the nation. Approved for both commercial and residential applications, it is sure to provide a safe and attractive solution to all of your railing needs.

CERTIFIED for the following building codes:
ICC-ES AC174
2006 International Building Code (IBC)
2006 International Residential Code (IRC)
1999 BOCA National Building Code

AVAILABLE
IN
**36" AND 42"
HEIGHTS**

SAFETY
 Aluminum "H" Channel
 Reinforcement (AHC6/8).
 Included in all top rails.
 Shown in T-Rail.
 Also fits 2" x 3.5" tops.



VR6/8C-3 Colonial Spindle Picket Shown With 2" x 3.5" Top and Bottom Rail
 Porch Post VRPP44-108 (Short Newel Posts VRNP44-48 Also Available)

VR6/8-3 Traditional Picket 1.5" x 1.5", 2" x 3.5" Top and Bottom Rail

THE SYSTEM



VRT6/8-3
Traditional Picket 1.5" x 1.5", T-Rail Top and 2" x 3.5" Bottom Rail



VRT6/8C-3
Colonial Spindle Picket T-Rail Top and 2" x 3.5" Bottom Rail

ACCESSORIES

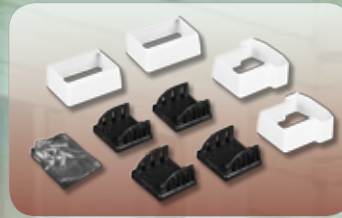

VR235TRK
T-RAIL HAND RAIL 2" x 3.5" KIT



VR235K
2" x 3.5" HAND RAIL KIT



VRSTRK
T-RAIL STAIR RAIL KIT



VRS235K
2" x 3.5" STAIR RAIL KIT



VRT45AK
T-RAIL 45° ADPT. KIT



VR23545AK
2" x 3.5" 45° ADPT. KIT



VRFBK
3 PIECE FOOT
BLOCK KIT



V44PS
4" x 4" POST SKIRT



VRPM
RAILING POST MOUNT SYSTEM



VRPMHC
HARDWARE-CONCRETE



VRPMHW HARDWARE-WOOD



VRNP44-48
4" x 4" x 48"
NEWEL POST



VRPP44-108
4" x 4" x 108"
PORCH POST

THE SYSTEM



QuickShip™

4 STYLES!
2 WIDTHS!
IN STOCK!
ALL THE TIME!

ASSEMBLED PANELS



VRT6/8-3 - Traditional Pkt. 1.5" x 1.5",
T-Rail Top and 2"x3.5" Bottom Rail, 6' or 8' Wide



VR6/8-3 - Traditional Pkt. 1.5" x 1.5",
2"x3.5" Top and Bottom Rail, 6' or 8' Wide



VRT6/8C-3 - Colonial Spindle Pkt.,
T-Rail Top and 2"x3.5" Bottom Rail, 6' or 8' Wide



VR6/8C-3 - Colonial Spindle Pkt.,
2" x 3.5" Top and Bottom Rail, 6' or 8' Wide

STAIR RAILS



VRST6/8-3
Traditional Stair Rail
Section, T-Rail Top and
2"x3.5" Bot. Rail, 6'/8' Wide



VRST6/8C-3
Colonial Stair Rail
Section, T-Rail Top and
2"x3.5" Bot. Rail, 6'/8' Wide

Also
Available
in 2" x 3.5"
Top Rail.

GATES



VRG-43



VRGC-43

POST CAPS AVAILABLE



SOLAR



EXTERNAL FLAT



BALL



COACHMAN



PALACE SOLAR



TEARDROP



GOTHIC



NEW ENGLAND

MIX 'N' MATCH™ COLORS AVAILABLE



White (WT)



Beige (BG)



Gray (GY)

ADA RAILING

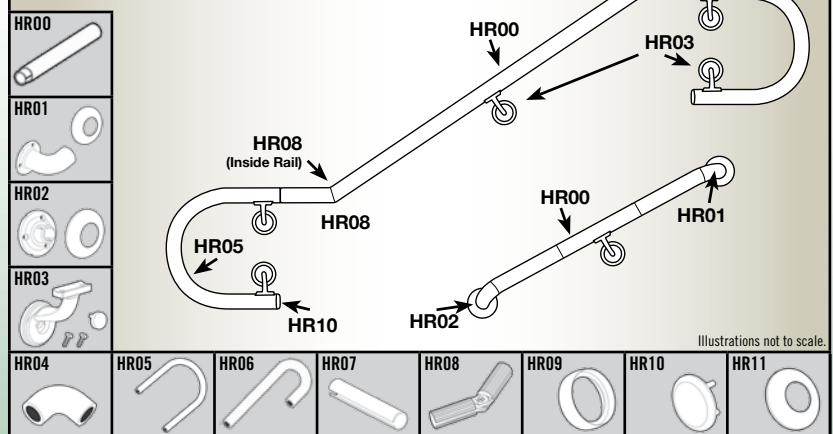

Item No.	Description	Item No.	Description
HR00	Rail with Stiffener - 104"	HR06	Post Return (Candy Cane)
HR01	90 Degree Wall Return Kit	HR07	Straight Joiner
HR02	Straight Wall Return Kit	HR08	Adjustable Joiner
HR03	Hand Rail Bracket Kit	HR09	Joint Ring
HR04	90 Degree Corner	HR10	Rail End Cap
HR05	End Loop 18" x 12" x 18"	HR11	Bracket/Wall Return Cover Plate

INSTALLATION



Installation Instructions

Tools Needed to Complete Installation:

- Measuring Tape
- Wrench Set
- Pencil
- Phillips Head Screwdriver or Screwdriver Bits
- Level
- Circular Saw With Carbide Tip Multi-purpose Blade
- 2" Wood Blocks for Ease of Determining Height of Sections

The following instructions will guide you through the AC174 approved installation of your new *Illusions*® Vinyl Railing System™. Testing was performed to evaluate compliance with ICC-ES AC174, *Acceptance Criteria for Deck Board Span Ratings and Guardrail Systems (Guards and Handrails)* which is ICC-ES acceptance criteria for recognition of compliance with the following building codes:

- ICC-ES AC174
- 2006 International Residential Code (IRC)
- 2006 International Building Code (IBC)
- 1999 BOCA National Building Code

ICC-ES-2995
CCRR-0143

This installation guide is a recommendation for meeting most code requirements. Always check your local building codes before starting a project and for determining the acceptable installation practices of your area. Read assembly instructions completely before beginning construction. Always wear protective goggles and gloves when installing a vinyl railing system.

IMPORTANT NOTE:

- When installing brackets to post mounts, use 1 inch screws provided.
- When installing brackets to vinyl sleeved over wood, use 1-1/2 inch screws provided.
- When securing rails to brackets, use 3/4 inch screws provided for all applications.

INSTALLATION



Illusions® Vinyl Post Sleeve Over Wood Posts

Typically, square 4" x 4" support posts are placed according to the length of railing desired and extend through the deck and then are cut to a height to receive the railing post. Square vinyl posts are then slid over the wooden posts, ready for railing sections to be installed.

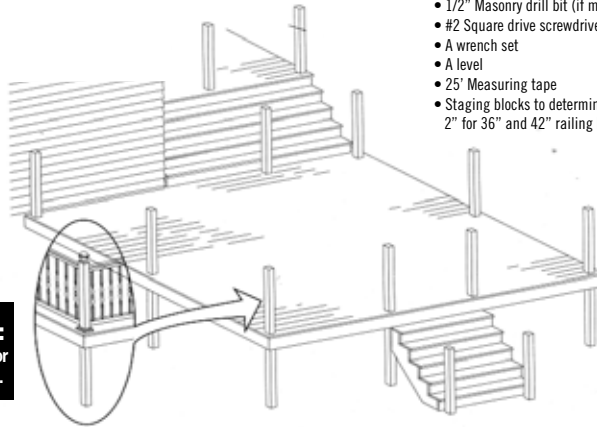

TOOLS NEEDED

- Cut off saw with fine tooth blade, and/or a
- Circular saw with a carbide tip multi-purpose blade
- Drill
- 1/2" Masonry drill bit (if mounting a post on concrete)
- #2 Square drive screwdrivers or screwdriver bits
- A wrench set
- A level
- 25' Measuring tape
- Staging blocks to determine the height of the railing; 2" for 36" and 42" railing heights

IMPORTANT NOTE:
Installer must consult local code officials for compliance to building code requirements.

Illusions® Wood Post Mount Installation Instructions for VRPM436 and VRPM442 with VRPMHW

- STEP 1** - Lay out the location of the post.
- Install at least 3" of blocking under the mounting location. Securely attach the blocking using reinforcement screws.
- STEP 2** - Using the leveling plate as a template, mark the locations of the 4 mounting holes to be drilled.
- Drill 4 holes through the decking and blocking using a 3/8" diameter drill bit.
- STEP 3** - Install the 4 leveling bolts into the post mount member.
- Place the leveling plate on the decking surface and align over the (4) drilled holes.
 - Place the post mount member on top of the leveling plate and align the (4) holes.
 - Adjust the leveling screws to ensure the post mount member is level.
- STEP 4** - Install the 4 mounting bolts with washers as shown.
- On the underside, place the back plate over the exposed mounting bolts. (Use the centered holes for in-line applications and the offset holes for corner applications).
 - Secure the back plate by using the supplied mounting nuts and washers.
- STEP 5** - Install the two guide blocks onto the post mount member. They should be positioned so that the screws from the railing brackets will screw into the guide blocks.
- Once the proper heights are established, drill a 1/8" dia. hole through both the guide block and the post mount member. Install the supplied guide block screws to hold the guide blocks in place.
- STEP 6** - Install the post profile and rail brackets according to *Illusions*® specifications.

Product Descriptions:

VRPM436:
Railing Post
4" x 4" x 36"

VRPM442:
Railing Post Mount
4" x 4" x 42"

VRPMHW:
Post Mount Hardware - Wood

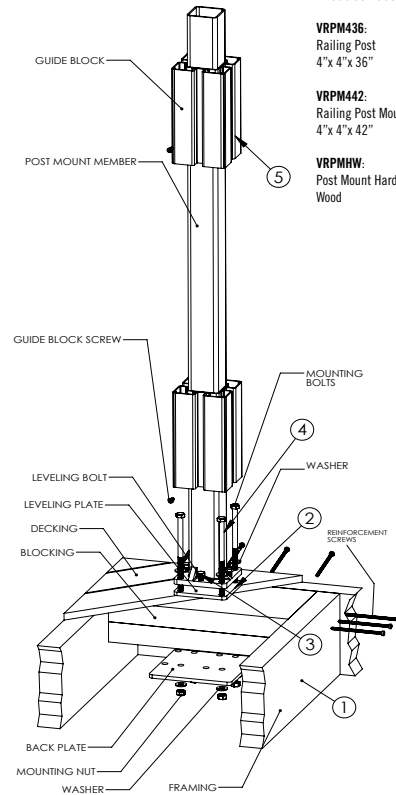

IMPORTANT NOTE:
Installer must consult local code officials for compliance to building code requirements.

INSTALLATION



Illusions® Concrete Post Mount Installation Instructions for VRPM436 and VRPM442 with VRPMHC

- STEP 1** - Lay out the location of the post.
- STEP 2** - Using the leveling plate as a template, mark the locations of the 4 mounting holes to be drilled.
- Drill 4 holes into the concrete using a 1/4" diameter masonry drill bit. The hole must be drilled to a minimum depth of 3-1/2".
 - Clean out the holes of all dust and debris.
- STEP 3** - Install the 4 leveling bolts into the post mount member.
- Place the leveling plate on the concrete surface and align over the (4) drilled holes.
 - Place the post mount member on top of the leveling plate and align the (4) holes.
 - Adjust the leveling screws to ensure the post mount member is level.
- STEP 4** - Install the 4 concrete bolts with washers as shown by applying downward pressure while turning in a clockwise direction.
- Continue to tighten the bolts until the heads are firmly seated. (Do not over tighten).
- STEP 5** - Install the two guide blocks onto the post mount member. They should be positioned so that the screws from the railing brackets will screw into the guide blocks.
- Once the proper heights are established, drill a 1/8" dia. hole through both the guide block and the post mount member. Install the supplied guide block screws to hold the guide blocks in place.
- STEP 6** - Install the post profile and rail brackets according to *Illusions*® specifications.

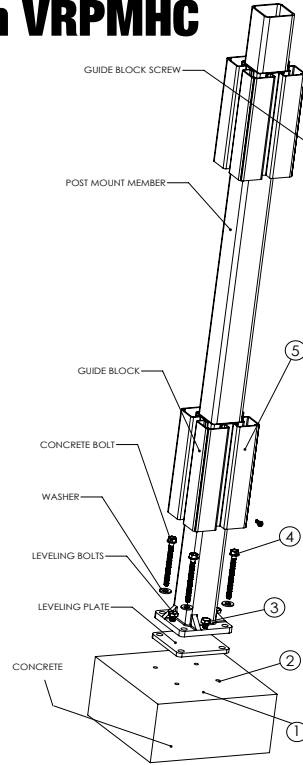

Product Descriptions:

VRPM436:
Railing Post
4" x 4" x 36"

VRPM442:
Railing Post Mount
4" x 4" x 42"

VRPMHC:
Post Mount Hardware -
Concrete

IMPORTANT NOTE:
Installer must consult local code officials for compliance to building code requirements.

Illusions® Straight Railing Bracket System Install Instructions for VR235K and VR235TRK

- STEP 1** - Using four (4) of the provided VRSSK screws (1 inch screws for post mount applications and 1-1/2 inch screws for vinyl sleeve over wood post applications), install the lower mounting plate to the post. The Mounting Plates should be centered on the post and the resting flange should be at the required height from the deck which is 2 inches.
- STEP 2** - Repeat Step 1 for installation of upper Mounting Plate. The distance between the top of the post to the top of resting flange is 5-1/2 inches. Repeat steps 1 and 2 on opposite Post.
- STEP 3** - Slide the bracket covers onto the railing section. Install the pre-assembled railing section into the mounting plates. Making sure that the rails sit on the resting flanges.
- STEP 4** - Install two (2) of the supplied 3/4 inch side screws into each mounting plate (one on each side) using the best slot location making sure that the screws engage into the aluminum H-channel (Code#-AHC6/8) in the rail. The mounting plates are slotted to allow for thermal expansion and contraction.
- STEP 5** - Slide the covers towards the post until they snap onto the mounting plates. You will hear an audible "click."
- STEP 6** - Choose any decorative post cap and footblock styles.

CENTER THE BRACKETS ON THE POST. DISTANCE FROM TOP OF POST TO TOP OF RESTING FLANGE IS 5-1/2 INCHES.

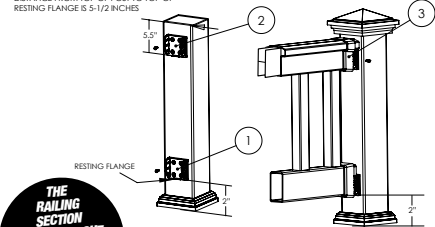

THE RAILING SECTION SHOULD BE CUT 3/8" SHORTER THAN THE DISTANCE BETWEEN POSTS

Product Descriptions:

VR235K:
2" x 3.5" Hand Rail Bracket Kit (4 Pc.)
Also available in:
Beige (VR235KBG)
Gray (VR235KGY)

VR235TRK:
T-Rail 2" x 3.5" Rail Bracket Kit (2 of ea.)
Also Available in:
Beige (VR235TRKBG)
Gray (VR235TRKGY)

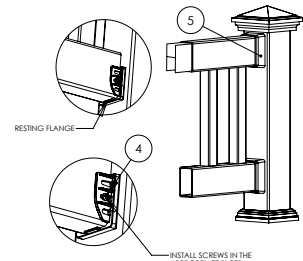

INSTALLATION



Illusions® Stair Railing Bracket Installation for VRS235K or VRSTRK

- STEP 1** - Cut top and bottom rail to desired length and angle to match the stair angle and the distance between the stair posts minus 3/8". Place a mounting bracket on each end of the rail, make sure the bottom rail sits on the resting flanges. Temporarily place into position at the desired distance above tread risers. The Mounting plates should be centered on the post and **the resting flange should be at the required height from the risers which is 2 inches.** Mark locations of the bottom of each mounting bracket and remove the section.
- STEP 2** - Using Four (4) of the provided VRSSK screws (1 inch screws for post mount applications and 1-1/2 inch screws for vinyl sleeve over wood post applications), install the lower mounting plate to the post. The Mounting plates should be centered on the post and aligned with the locations marked in Step 1.
- STEP 3** - Repeat step 1 and 2 for upper rail. **The distance between the top of the post to the top of resting flange is 5-1/2 inches.**
- STEP 4** - Slide the bracket covers onto the railing section. Install the pre-assembled *Illusions*® railing section into the mounting plates. Making sure that the rails sit on the resting flanges.
- STEP 5** - Install two (2) of the supplied 3/4 inch side screws into each mounting plate (one on each side) using the best slot location making sure that the screws engage into the aluminum H-channel (Code#-AHC6/8) in the rail. The mounting plates are slotted to allow for thermal expansion and contraction.
- STEP 6** - Slide the covers toward the post until they snap onto the mounting plates. You will hear an audible "click."
- STEP 7** - Choose any decorative post cap and footblock styles.

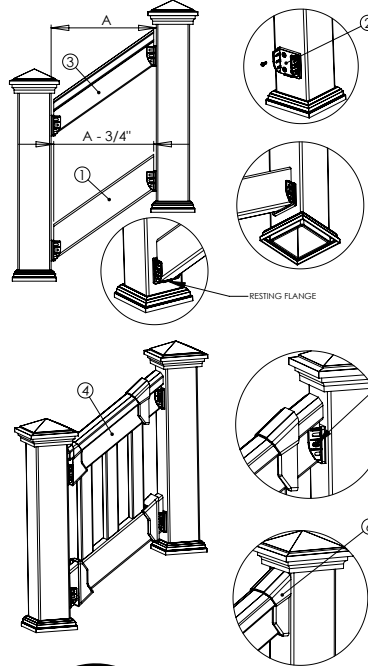

THE RAILING SECTION SHOULD BE CUT 3/8" SHORTER THAN THE DISTANCE BETWEEN POSTS

Product Descriptions:

VRS235K:
2" x 3.5" Stair Rail Bracket Kit (4 Pc.)
Also available in:
Beige (VRS235KBG)
Gray (VRS235KGY)

VRSTRK:
T-Rail 2" x 3.5" Stair Rail Bracket Kit (2 of ea.)
Also Available in:
Beige (VRS235TRKBG)
Gray (VRS235TRKGY)



QuickShip™ Assembled Panels In Stock All The Time

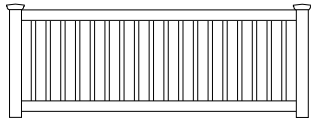

VR6/8-3 - Traditional Pkt. 1.5" x 1.5", 2" x 3.5" Top and Bottom Rail, 6' or 8' Wide

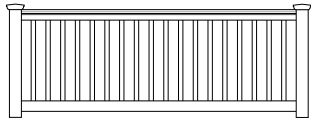

VRT6/8-3 - Traditional Pkt. 1.5" x 1.5", T-Rail Top and 2" x 3.5" Bottom Rail, 6' or 8' Wide

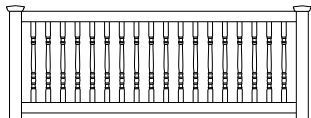

VR6/8C-3 - Colonial Spindle Pkt., 2" x 3.5" Top and Bottom Rail, 6' or 8' Wide

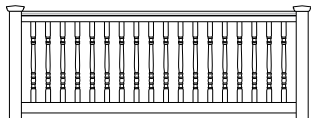

VRT6/8C-3 - Colonial Spindle Pkt., T-Rail Top and 2" x 3.5" Bottom Rail, 6' or 8' Wide

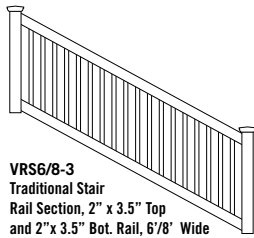

VRS6/8-3 Traditional Stair Rail Section, 2" x 3.5" Top and 2" x 3.5" Bot. Rail, 6' or 8' Wide

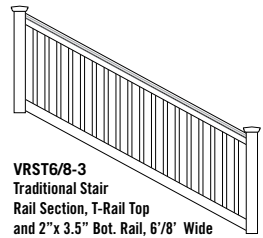

VRST6/8-3 Traditional Stair Rail Section, T-Rail Top and 2" x 3.5" Bot. Rail, 6' or 8' Wide

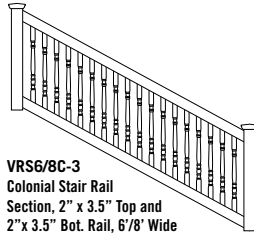

VRS6/8C-3 Colonial Stair Rail Section, 2" x 3.5" Top and 2" x 3.5" Bot. Rail, 6' or 8' Wide

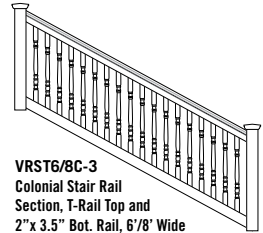

VRST6/8C-3 Colonial Stair Rail Section, T-Rail Top and 2" x 3.5" Bot. Rail, 6' or 8' Wide

Illusions® Vinyl Railing System™

1-800-339-3362 • www.IllusionsVinylRailing.com

COMMERCIAL RAILING APPLICATIONS



AFTER DOING THE RESEARCH, I'VE DECIDED THAT ILLUSIONS® VINYL RAILING IS HANDS DOWN THE BEST CHOICE FOR THE MIDLAND COUNTY HOSPITAL PROJECT. THE AC174 CERTIFICATION AND THE MIX 'N' MATCH™ COLORS FIT PERFECTLY!
- JAMES



Illusions® Vinyl Railing
Just Built Better

CERTIFIED
ICC-ES AC174
2006 INTERNATIONAL RESIDENTIAL CODE (IRC)
2006 INTERNATIONAL BUILDING CODE (IBC)
1999 BOCA NATIONAL BUILDING CODE
Illusions® Vinyl Railing System™
meets the highest building codes in the nation!

MATERIALS NEEDED FOR CERTIFIED ICC-ES AC174 RAILING IN

ITEM	USAGE	QUANTITY
Bracket Kits	Required. Available in 6" or 8" Panels, T-Rail or 2" x 3.5" Top Rail, 42" Height. Available in White (WT), Beige (BG), Gray (GY) and TO MEET CERTIFICATION REQUIREMENTS.	26 VRT6-3 BEIGE
Screw Kit with Required Installation Instructions	Required. One screw kit per section. Needs to match top-rail style of ordered panels.	25
Foot Blocks	Required. One screw kit per section. Required installation instructions included with every screw kit.	25
4" x 4" Posts	Required. One per section.	25
Hardware and Installation	Required. 38" for 36" high railings and 44" for 42" high railings.	25
Post Skirts	Required. One Per Post. Available in 36" and 42" height for either 4" Posts.	26
Extra Long Posts (4' or 8')	Recommended. One Per Post. Available in 8 styles including Solar Caps.	26 MASONRY
Porch Posts (Left Photo)	Recommended. One Per Post.	26 BALL CAPS
Newel Posts (Right Photo)	As needed. Decorative load bearing accent post. Only available in 4" x 4" x 108".	26
Aluminum H-Channel	As needed. Decorative post for both Hand/Stair Rail applications. Only available in 4" x 4" x 48".	4 BEIGE 4 WHITE
Glue	Optional. Included in all top rails. Optional for bottom rails.	4 GRAY
+	Required Component for ICC-ES AC174 Certified	-

PHOTO COURTESY OF ILLUSIONS VINYL RAILING

